

This device complies with part 15 of the FCC Rules. Operation is subject to the following two conditions: (1) This device may not cause harmful interference, and (2) this device must accept any interference received, including interference that may cause undesired operation.

BR-20 Magnetic Card Reader

Installation and Maintenance

1. General:

The BR-20 magnetic stripe card reader is designed for reading standard or high-coercivity magnetic stripe cards. The BR-20 also provides a 12-key keypad for PIN entry and provides a TTL interface. The following paragraphs describe instructions for installing and maintaining the card reader.

2. Mounting the reader:

Find a suitable location to anchor the reader mounting bracket. The reader may be mounted vertically or horizontally. See recommended orientation. The mounting of the reader does not require a junction box. However, rigid conduit is required for outdoor application. A single gang junction box may be used to provide a transition to rigid conduit. If a single gang junction box is used, a wall plate (optional) may be used to cover the junction box. The reader is then secured to the mounting bracket using a screw. Refer to figures for reader dimensions and typical junction box usage.

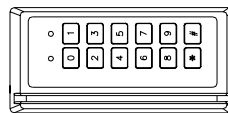
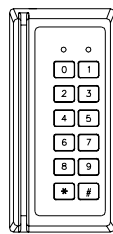

Recommended

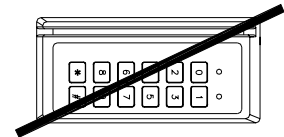

Not Recommended

3. Reader Wiring:

The reader has a RJ-11 modular jack for easy field connection. A small piece of pre-terminated cable is supplied with each standard reader for field wiring. The pre-terminated cable has nonstandard color. Refer to pin number if the pre-terminated cable is not used. Cable with wires of 24AWG or larger are recommended for field wiring.

4. Connecting the Keypad:

The BR-20 provides a 12-key keypad for PIN entry. The flex tail of the keypad is connected to the electronic board via a ZIF (zero insertion force) connector. The contacts are engaged/disengaged by a moving slide. Care must be exercised when connecting and disconnecting the keypad. When connecting the keypad to the board, open the slide as shown. Insert the electronics into the housing and insert flex tail in the ZIF connector. Then, close the slide to engage the contacts. To disconnect the keypad, follow the previously described steps in reverse.

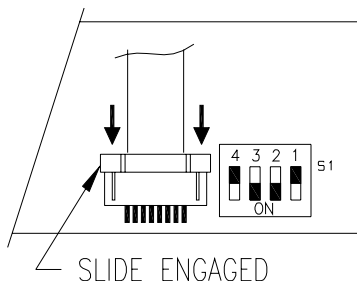
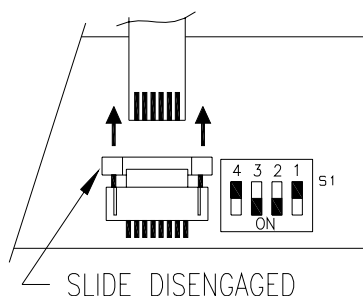

CAUTION: DO NOT DISCONNECT KEYPAD WITHOUT DISENGAGING THE CONNECTOR!

CONFIDENTIAL: For installation and maintenance use only. **DO NOT** distribute.

Information subject to change without notice.

5. Weather Proofing the Reader:

The reader is rated to operate over an extended temperature range and the electronics are conformal coated against moisture. If the reader is expected to be exposed to weather, use the dielectric grease to coat the field connections. After field connection/configuration is made, the grease is to be applied on the DIP switch slides, keypad connection, and the RJ-11 jack to seal out moisture.

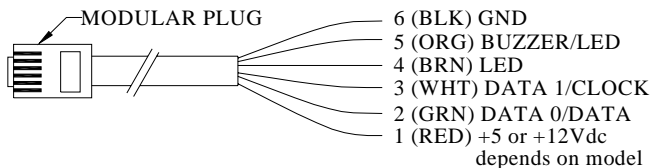
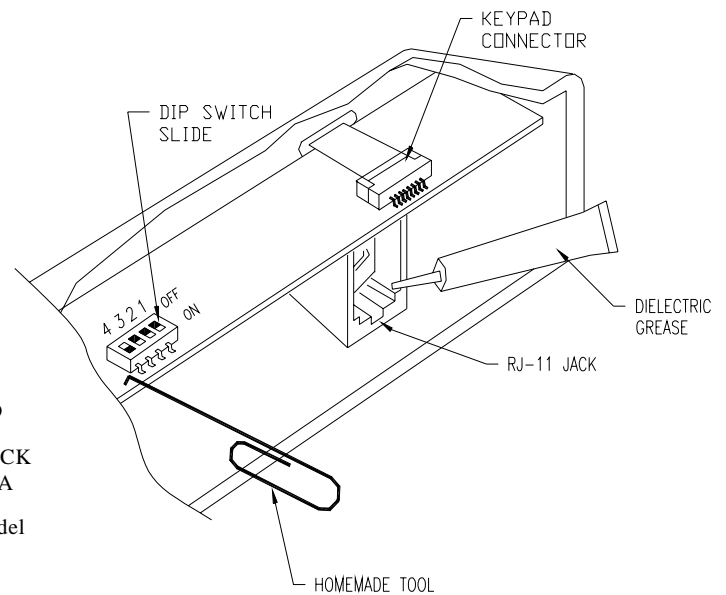

6. TTL Interface:

The TTL interface has the standard 5-wire interface widely used in the access control application. In addition, an input to control the buzzer is provided. Cable with minimum of 24AWG wires should be used.

Pin #	Wire	Signal	Description
1	Red	Vin	Power supply input, 5Vdc or 12Vdc, Model dependent
2	Green	/Data (Mag) or /Data 0 (Wieg)	Reader data output
3	White	/Clock (Mag) or /Data 1 (Wieg)	Reader data output
4	Brown	LED	LED input 1-wire control: 0V turns on the green LED 5V turns on the red LED 2-wire control: 0V turns on the red LED
5	Orange	Buzzer/LED	Buzzer/LED input 1-wire control: 0V turns on the buzzer 2-wire control: 0V turns on the green LED
6	Black	Signal Ground	Power supply return, DC ground

7. Grounding the Reader:

To avoid having ESD (electrostatic discharge) interfering with the operation of the reader, the reader casing shall be grounded. This can be accomplished by tying the mounting bracket to earth ground locally (e.g. grounded conduit).

8. DIP switch/Jumper setting:

The DIP switch on the BR-20 reader is used to select a preset format, the functions for the LED and buzzer, and the output signal format, etc. The preset format determines how the card is interpreted. Refer to the format specification for detail. The settings are for STANDARD models ONLY.

FORMAT	SW-4	SW-3	SW-2	SW-1	OUTPUT	LED	BUZZER	TAMPER
0	ON	ON	ON	ON	DATA 1/DATA 0	1-WIRE LED	YES	NO
1	ON	ON	ON	OFF	CLOCK/DATA	1-WIRE LED	YES	NO
2	ON	ON	OFF	ON	CLOCK/DATA	1-WIRE LED	YES	YES
3	ON	ON	OFF	OFF	CLOCK/DATA	1-WIRE LED	YES	NO
4	ON	OFF	ON	ON	DATA 1/DATA 0	1-WIRE LED	YES	NO
5	ON	OFF	ON	OFF	DATA 1/DATA 0	1-WIRE LED	YES	NO
6	ON	OFF	OFF	ON	DATA 1/DATA 0	1-WIRE LED	YES	NO
7	ON	OFF	OFF	OFF	DATA 1/DATA 0	1-WIRE LED	YES	NO
12	OFF	OFF	ON	ON	CLOCK/DATA	2-WIRE LED	NO	NO
13	OFF	OFF	ON	OFF	DATA 1/DATA 0	2-WIRE LED	NO	NO
15	OFF	OFF	OFF	OFF	CLOCK/DATA	1-WIRE LED	YES	YES

9. BR-20 Standard Format Code Summary:

The following formats are supported in standard models (31002-8000/31012-8000).

Unless otherwise indicated, the LED input line controls both LEDs (low=green, high=red); the BUZZER input controls the buzzer (low = activate); a good read is signaled by a flash of the green LED; a bad read is signaled by a flash of the red LED and a double beep of the buzzer.

- Format 0 - 32-bit Wiegand compatible output from standard Northern Computer mag card. 16-bit facility code and 16-bit user ID. Reverse read and error filter is enabled. Tamper monitor disabled.
- Format 1 - Basic mag-stripe data output: send track 2 data without any verification or formatting using **CLOCK/DATA** signaling. All reads are "good", card data is sent as is. Tamper monitor disabled.
- Format 2 - Mag-stripe data output with zero trim using **CLOCK/DATA** signaling. All reads are "good", trims excess zero bits, otherwise sends data as is. Tamper monitor enabled.
- Format 3 - Mag-stripe data output with zero trim, reverse read correction, and error filter enabled using **CLOCK/DATA** signaling. Tamper monitor disabled.
- Format 4 - 26-bit Wiegand (8-bit fac. and 16-bit ID) compatible output from cards with 8 or more digits or AMC encoding. See Format 5 for digit usage. Tamper monitor disabled.
- Format 5 - 34-bit Wiegand (12-bit fac. and 20-bit ID) compatible output from cards with 8 or more digits or AMC encoding.

Digits in mag card	Facility Code			User ID		
	Digits	26-bit Range	34-bit Range	Digits	26-bit Range	34-bit Range
8	1-3	000-255	000-999	4-8	00000-65535	00000-99999
9	1-3	000-255	000-999	4-9	000000-065535	000000-999999
10	1-4	0000-0255	0000-4097	5-10	000000-065535	000000-999999
11 or more	1-5	00000-00255	00000-04097	6-11	000000-065535	000000-999999
AMC card	1-6	000000-000255	000000-004097	7-12	000000-065535	000000-999999

- Format 6 - 26-bit Wiegand compatible output from standard Norther Computer 32-bit mag-stripe card. The lower 8 bits of the 16-bit facility code is used as facility code. The 16-bit user ID is unaltered. Reverse read and error filter is enabled. Tamper monitor disabled.
- Format 7 - Mag-stripe data output with zero trim and reverse read correction using **DATA 1/DATA 0** signaling. Tamper monitor disabled.
- Format 12 - Mag-stripe data output: send track 2 data without any verification or formatting using **CLOCK/DATA**. All reads are "good", card data is sent as is. 2-wire LED control. No buzzer control. Tamper monitor disabled.
- Format 13 - Mag-stripe data output with zero trim and reverse read correction using **DATA 1/DATA 0** signaling. 2-wire LED control. No buzzer control. Tamper monitor disabled.
- Format 15 - (factory test) mag-stripe data output: verify track 2 data and send track 2 data without formatting using **CLOCK/DATA** signaling. Zero trim, reverse read, bad card filter, and tamper monitor option are enabled.

10. Keypad Data and Tamper Monitor Signalling:

Keypad data and tamper monitor status are transmitted on the data lines as 8-bit blocks. They are encoded and sent using the same signaling method as selected for the card data output (clock/data or data 1/data 0). Card data, tamper status data, and keypad data blocks are separated by a minimum of 100 milliseconds. See following for codes:

10110000 - 0 (ASCII '0', odd parity, MSB first)	00110001 - 1 (ASCII '1', ...)
00110010 - 2 (ASCII '2', ...)	10110011 - 3 (ASCII '3', ...)
00110100 - 4 (ASCII '4', ...)	10110101 - 5 (ASCII '5', ...)
10110110 - 6 (ASCII '6', ...)	00110111 - 7 (ASCII '7', ...)
00111000 - 8 (ASCII '8', ...)	10111001 - 9 (ASCII '9', ...)
00101010 - * (ASCII '*', ...)	00100011 - # (ASCII '#', ...)
11010011 - SAFE (ASCII 'S', ...)	01010100 - ALARM (ASCII 'T', ...)

11. Reader Verification:

The reader performs a self-test when power is first applied to the unit. If power-on test is successfully completed, the reader will turn on both LEDs for approximately 1 second and sound the buzzer for 1 short beep. Then the reader is ready for normal operation.

If further verification of the reader hardware is needed, the reader may be temporarily set to format 3. With this format selected, the reader will read and verify standard ANSI track 2 encoded card. If no read error is detected, the green LED will flash. Otherwise, the red LED will flash and the buzzer will sound two short beeps to indicate an error. The LED input can be used to verify the LED function; and the buzzer input for the buzzer function. The reader will echo a key press with a brief flash of both LEDs and a short beep of the buzzer. Reset to the required format for normal operation after test.

12. Maintenance:

The reader is designed to provide continuous service with minimal routine maintenance. However, contaminants (such as magnetic oxides from badges and dirt) tend to accumulate on the read head. Without regular cleaning, these contaminants will shorten the read head life and increase the probability of card read error. A maintenance schedule should be developed base on the card reader environment (dirty or clean) and the usage frequency (light traffic or heavy traffic). Extreme case may require daily cleaning.

Head cleaning may be done by using a disposable, pre-saturated magnetic head cleaning card. These cards are readily obtainable from a number of sources (e.g. Clean Team Co., www.cleanteam.com, 800-888-8830; KIC Products, www.kicproducts.com, 207-514-7030; System ID, www.systemid.com, 888-648-4452).

The reader exterior surface is covered with high strength polymer and polyester membrane. It may be cleaned with a soft cloth and mild detergent if required.

13. Specifications:

The reader is for use in low voltage, class 2 circuits only.

Power:	Voltage -	5Volt Model: 5.8 Vdc (4.9 to 6.4 Vdc) 12Volt Model: 12 Vdc (10.2 to 13.8 Vdc)
	Current -	50mA (25mA typical.)
Data output:	Data 1/0 pair or clock/data	
	Timing-	clock/data - period 1mS setup/hold time 400uS, clock pulse width 200uS typical
		data 1/0 - period, 1mS for Wiegand data, 1mS for mag stripe data pulse width 50uS typical
LED input:	1-wire mode:	input not driven: LEDs OFF input > 3.5Vdc: Red LED ON input < 0.8Vdc: Green LED ON
Buzzer/LED:	2-wire mode:	input < 0.8Vdc: Red LED ON
	1-wire mode:	input not driven or > 3.5Vdc: buzzer OFF input < 0.8Vdc: buzzer ON
Mechanical:	2-wire mode:	input < 0.8Vdc: Green LED ON
	Dimension -	1.95" (50mm)W x 1.30" (33mm)H x 5.50" (140mm)L
	Weight -	10 oz. (284 g) nominal
	Material -	Case, Die cast aluminum, gray powder coat standard. Mounting, stainless steel Wall plate, 18 CRS, gray powder coat standard
Card:		75 bpi, ANSI X4.16, Track 2 standard, Speed 3 to 50 ips
Read Head:		1,000,000 passes typical.
Distance:		500' (152m) with 18 AWG wires.
Environmental:	Temperature:	-55 to +85 degrees C, storage -40 to +75 degrees C, operating
	Humidity:	0-95% RHNC 100%

14. Product Identification:

Reader product identification is provided on labels. These labels have information on program ID, revision, product ID, supply voltage, and copyright notice. These labels are located on the circuit board and the back of the reader.

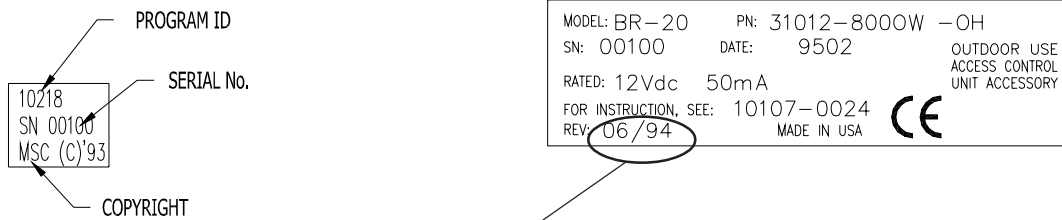

Manual revision, See appropriate manual for FORMAT information.

15. Reader Mounting Dimensions:

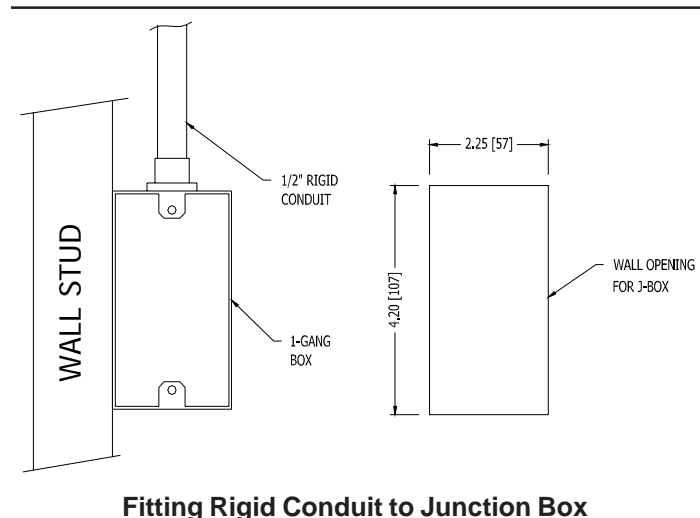
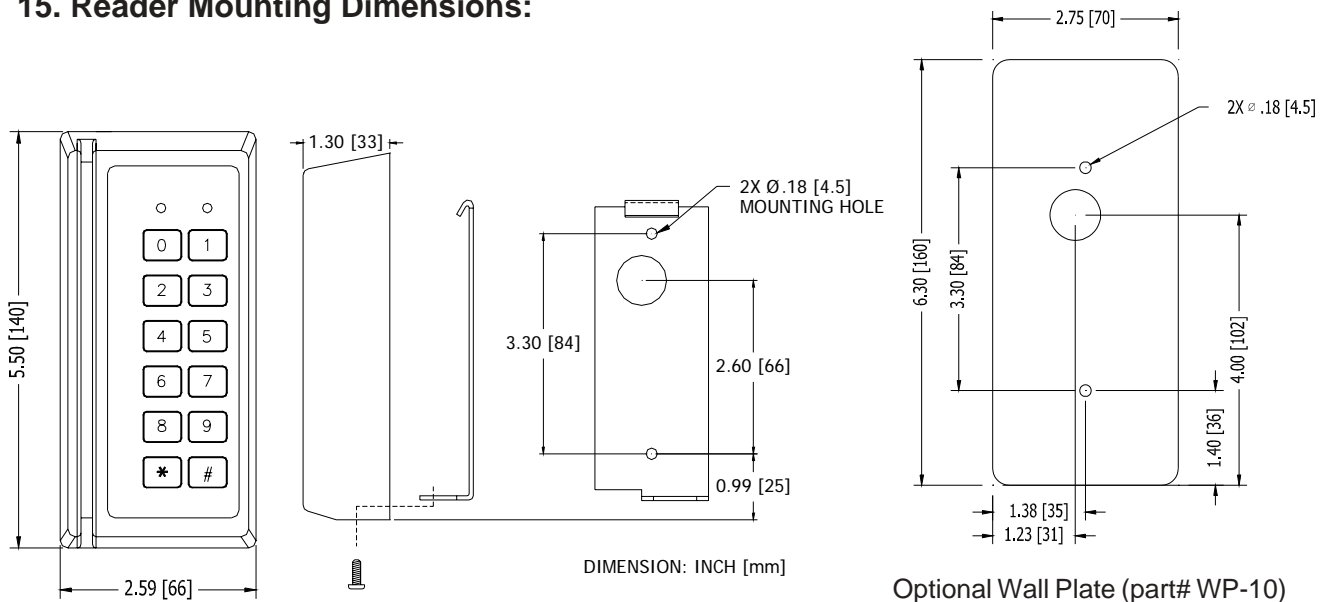

Information subject to change without notice.

Warranty

Mercury Security Corporation warrants the product is free from defects in material and workmanship under normal use and service with proper maintenance for two years from the date of factory shipment. Mercury Security Corporation assumes no responsibility for products damaged by improper handling or installation. This warranty is limited to the repair or replacement of the defective unit.

There are no expressed warranties other than set forth herein. Mercury Security Corporation does not make, nor intends, nor does it authorize any agent or representative to make any other warranties, or implied warranties, and expressly excludes and disclaims all implied warranties of merchantability or fitness for a particular purpose.

Returned units are repaired or replaced from a stock of reconditioned units. Returns must be accompanied by a return authorization number (RMA) obtained from customer service, and prepaid postage and insurance.

Liability

The card readers should only be used to control exits from areas where an alternative method for exit is available. This product is not intended for, nor is rated for operation in life-critical control applications. Mercury Security Corporation is not liable under any circumstances for loss or damage caused by or partially caused by the misapplication or malfunction of the product. Mercury Security Corporation's liability does not extend beyond the purchase price of the product.